

# Behavior of foundation piles resisting lateral forces in soft soil

*by* Ahmad Saiful Haqqi

---

**Submission date:** 25-May-2023 01:39PM (UTC+0700)

**Submission ID:** 2101434197

**File name:** Artikel.pdf (907.82K)

**Word count:** 2988

**Character count:** 15890

## Behavior of foundation piles resisting lateral forces in soft soil

Rusdiansyah\*, Muhammad Afief Ma'ruf, Nurul Hidayah

Civil Engineering Program, Universitas Lambung Mangkurat  
Jl. Jenderal Achmad Yani Km 35,5 Banjarbaru, Kalimantan Selatan – 70714  
E-mail: [rusdiansyah74@ulm.ac.id](mailto:rusdiansyah74@ulm.ac.id)

### ABSTRACT

The role of the foundation in construction is crucial. Foundation planning aims to ensure that it can support loads up to a specified safety limit, including the maximum load that may be encountered. The foundation serves as the lower structure that interacts with the soil, providing stability and support for the superstructure. In this study, the analysis focused on the bearing capacity of the pile foundation under lateral forces. The Brinch Hansen method was employed to determine the allowable lateral bearing capacity, while the computer application was used to calculate the lateral deflection. Various pile lengths, such as 20m, 25m, 30m, 34m, and 40m, as well as different dimensions, including circular piles with diameters D30, D35, D40, and square piles measuring 30x30, 35x35, and 40x40, were considered. The analysis revealed that square cross sections exhibited greater allowable lateral bearing capacity compared to circular cross sections. The square sections showed smaller lateral deflection values in comparison to the circular sections.

Keywords: Pile Foundation, Lateral Load, Deflection, Brinch Hansen Method, Computer Application Method

### 1. INTRODUCTION

The foundation plays a critical role in civil construction as it is responsible for transmitting the loads from the structure and the building above it to the underlying subsoil. It serves as an underground structure that supports both the lower structure and the superstructure. By interacting with the soil, the foundation ensures stability and security for the entire construction.

Piles are a type of deep foundation that can be constructed using various materials, including wood, concrete, steel, and composite materials. In addition to being designed to withstand vertical or axial loads, pile foundations must also consider lateral loads.

3 These lateral loads can originate from various sources, such as earth pressure acting on retaining walls, wind forces, seismic forces, and eccentric loads on columns. Therefore, the design of pile foundations involves addressing both the vertical and lateral load requirements to ensure the stability and integrity of the structure.

2 The estimated value of the lateral bearing capacity of a pile foundation can be determined by analyzing the physical characteristics of the foundation and soil parameters, using principles of mechanics. Conventional methods, such as the Brinch Hansen method is suitable for calculating the ultimate lateral resistance of short piles and offers the advantage of applicability to various soil conditions, including homogeneous soils, soils with  $c-\phi$  (cohesion and friction angle), and layered soils. However, it should be noted that this method is applicable only to short piles and may not be suitable for analyzing the behavior of longer piles.

This study investigated the impact of pile depth and dimensions on the design of pile foundations to resist lateral forces at the Customs Building in Banjarmasin. This study enhances our understanding and determines the influence of pile length and foundation dimensions on the design of pile foundations for lateral force resistance. The design process utilized the Conventional Brinch Hansen method and the Allpile V 7.3B Computer Application method to evaluate the pile foundation's ability to withstand lateral forces acting on the foundation.

## 2. LITERATURE REVIEW

### Conventional Method (*Brinch Hansen*)

20 The method described is particularly valuable for assessing the deflection of piles under moderate lateral loads. In this calculation, the pile is considered as a fixed cantilever structure at a depth of  $z_f$ .

The deflection of a free pile can be determined using the equation.

$$y = \frac{H(e + Z_f)^3}{3 E_p I_p}$$

On the other hand, the deflection of a fixed-end pile can be expressed by the equation:

$$y = \frac{H(e + Z_f)^3}{12 E_p I_p}$$

Where:  $H$  = lateral load (kN),  $E_p$  = elastic modulus of pile,  $I_p$  = inertia of pile,  $E$  = distance of lateral load on ground surface,  $z_f$  = distance of pinch point from ground

Surface.

The Brinch Hansen (1961) method was used to calculate the ultimate lateral resistance of short piles. This method is based on earth pressure theory and offers the advantage of being applicable to various soil conditions, including homogeneous soils, soils with cohesion and friction angle (c-Ø), and layered soils. The equation for calculating the ultimate lateral resistance (P<sub>su</sub>) of short piles is given as:

$$P_{su} = \sigma_1 v . Kq + c . Kc$$

Where K<sub>c</sub> and K<sub>q</sub> are functions of Ø and x/D shown in Figure 1 below.

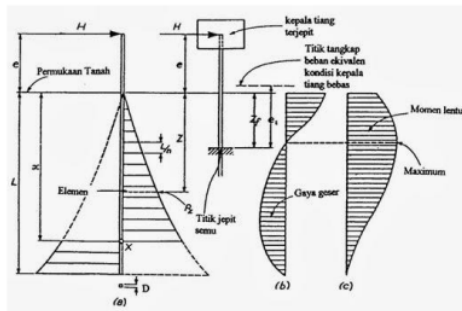

**Figure 1** Brinch Hansen Method (1961)

When considering piles that resist lateral forces in soils with cohesion and friction, (soil c – φ) the equation for the ultimate lateral soil resistance at any depth z, based on lateral earth pressure theory, is as follows:

Piles that resist the lateral forces are located on soils that have cohesion and friction (soil c – φ). The ultimate lateral soil resistance equation at any depth z based on the lateral earth pressure theory is presented as follows::

$$p_u = p_o K_q + c K_c$$

Where P<sub>o</sub> = vertical overburden pressure, c = cohesion, K<sub>o</sub> K<sub>q</sub> = functional factors of φ and z/d

If the pile head is clamped (pin pile), the equivalent height (e<sub>1</sub>) of the force H on the ground surface can be determined by the expression:

$$e_1 = \frac{e + z_f}{2}$$

Where: e = distance of the force H from the ground surface, z<sub>f</sub> = distance from the ground surface to the pinch point

The z<sub>f</sub> distance is unknown at this stage. For practical purposes, z<sub>f</sub> is taken to be 1.5 m for sandy/stiff clay soils and 3 m for soft clay/silt soils.

**P-Y Method on Computer Program**

The p-y curve method is one of the settlement methods used to analyze the lateral deflection of piles. This method establishes the relationship between lateral load and deflection between the soil and the pile, which is represented by the p-y curve. The p-axis represents the lateral soil resistance per unit length of the pile, and the y-axis represents the lateral deflection of the pile.

This equation was used to solve the problem using the p-y curve method.

$$\frac{d^2}{dx^2} \left( E_p I_p \frac{d^2 y}{dx^2} \right) + P_x \left( \frac{d^2 y}{dx^2} \right) - p - W = 0$$

With:  $P_x$  = axial load,  $y$  = lateral deflection that occurs in depth  $x$  at the length of the pile  $L$ ,  $p$  = soil resistance,  $W$  = lateral load distributed along the pile  $E_p$  = elastic modulus of the pile,  $I_p$  = pile moment of inertia

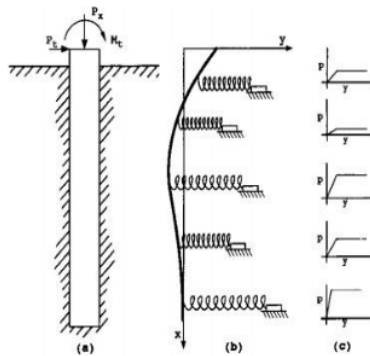

**Figure 2** The Illustration of Lateral Loading on a pile (Prakash dan Sharma, 1990)

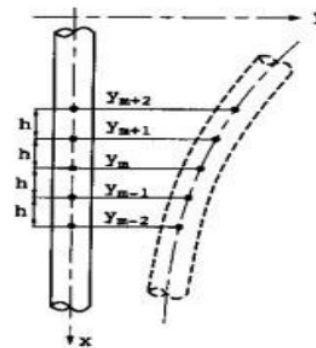

**Figure 3** Deflection on the pile per depth (Prakash dan Sharma, 1990)

Figures 2 and 3 visually demonstrate the deflection of a pile resulting from lateral loads or pressure applied to the pile. The presence of soil pressure leads to distinct deflection patterns at various depths. These figures emphasize the non-uniform nature of pile deflection along its length due to the varying soil conditions and encountered lateral loads.

The p-y curve method can also be solved numerically, utilizing the computer program. It can handle various foundation types, including drilled piles, steel pipe piles, H piles, wooden piles, shallow foundations, and more. It allows for the definition of new pile types and input parameters based on local practices and experience. The output of computer program consists of a p-y curve and several pile behaviors depicted in a graph

that includes the relationship between the load and deflection at each depth, the bending moment, and the shear force occurring on the pile. The analysis conducted using the p-y curve method generated a graphical representation of the relationship between lateral loads and the corresponding deflections at different depths.

### 3. DESIGN METHOD

#### Site

The design location or object being analyzed is the Customs Office Development Project on Jl. A. Yani KM. 2 City of Banjarmasin, South Kalimantan.

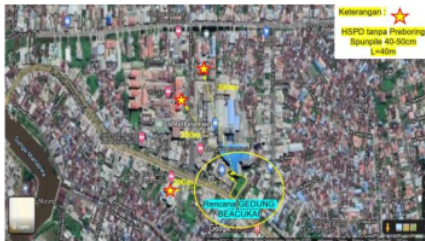

**Figure 4** The Site Plan Location



**Figure 5** The Current Building

#### The Design Method and Analysis

An analysis was conducted to calculate the lateral allowable pile bearing capacity and lateral deflection using two methods: the P-Y method with Computer Application and the Conventional method (Brinch Hansen). The analysis considered various pile diameters (D30, D35, D40, 30x30, 35x35, 40x40) and lengths (L) of 20m, 25m, 30m, 34m, and 40m.

In the design, the analysis using the Conventional, Brinch Hansen method involved plotting the relationship between Permitted Lateral Bearing Capacity and Pile Length, L, considering all variations of Circular and Square type pile dimensions. Conversely, the analysis carried out using the P-Y method with computer applications, specifically computer program, entailed creating a graph depicting the relationship between Lateral Deflection and Pile Length, L, for different Circular and Square type pile dimensions.

#### 4. RESULTS AND DISCUSSIONS

The soil investigation data utilized for the analysis comprises two types, namely Cone Penetrometer Test data and NSPT data. These two investigation data sets are presented in Figure 6, conducted by the service provider PT. Somif Borneo Perkasa on August 2, 2020. Additionally, supporting data such as the parameter values for each soil layer are provided in Table 1.

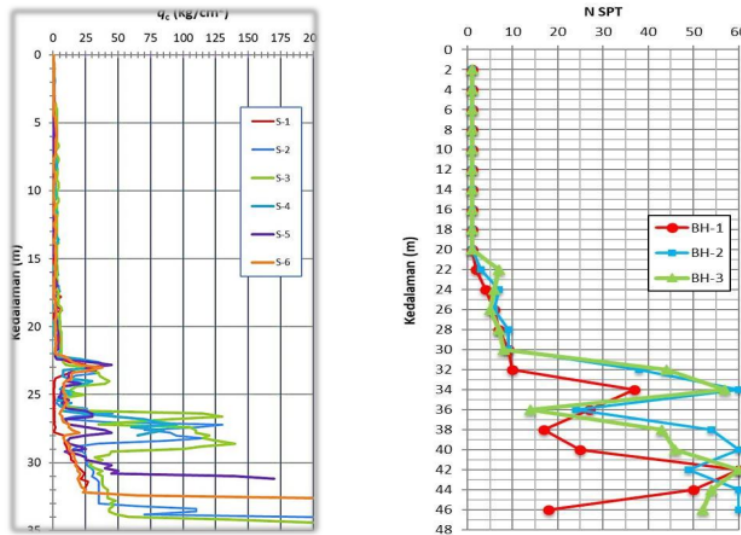

Figure 6 Cone Penetrometer Test Soil (CPT) and N value in SPT

Table 1 The value of each parameter in every soil layer

| Soil Type | H (m) | $\gamma$ (kN/m <sup>3</sup> ) | $c_u$ (kN/m <sup>2</sup> ) | $\phi$ (°) |
|-----------|-------|-------------------------------|----------------------------|------------|
| Silt      | 25    | 16                            | 24                         | 20         |
| Clay      | 9     | 16                            | 96                         | 22         |
| Sand      | 12    | 18                            | 0                          | 25         |

Source: Observation Results

To acquire secondary data concerning the lateral load of a single pile, a recalibration is performed using the values of the group lateral load, namely  $V = 50$  kN,  $H = 1500$  kN, and  $M_{max} = -67.6761$  kN.m. The calculation outcomes are presented in Table 2 as follows.

Table 2 Secondary data for lateral loads on a single pile.

| V (kN) | H (kN) | $M_{max}$ (kN.m) |
|--------|--------|------------------|
| 5,55   | 166,7  | -7,519           |

Following the acquisition of secondary data on the lateral load of a single pile, the data were subsequently entered into the software to compute the lateral deflection.

**2**  
The results of lateral bearing capacity calculations.

By performing the calculation of the lateral bearing capacity for various types of pile dimensions (circular and square), including circular pile sizes D30, D35, D40, and square types 30x30, 35x35, 40x40, alongside different pile lengths such as 20m, 25m, 30m, 34m, and 40m, the resulting calculations are presented in Table 3 as follows.

**Table 3** The results of lateral bearing capacity calculations with variations in pile dimensions and pile length, L.

| L (m) | H izin (ton) |      |      |        |       |       |
|-------|--------------|------|------|--------|-------|-------|
|       | Circular     |      |      | Square |       |       |
|       | D30          | D35  | D40  | 30x30  | 35x35 | 40x40 |
| 20    | 2.04         | 2.78 | 3.63 | 2.90   | 3.95  | 5.16  |
| 25    | 2.04         | 2.78 | 3.63 | 2.90   | 3.95  | 5.16  |
| 30    | 2.31         | 3.14 | 4.11 | 3.33   | 4.54  | 5.93  |
| 34    | 2.43         | 3.30 | 4.31 | 3.53   | 4.81  | 6.28  |
| 40    | 2.32         | 3.16 | 4.13 | 3.35   | 4.56  | 5.96  |

➤ Lateral Force Safety Check on Pile Foundation

Maximum lateral force in the x direction on the pile,  $F_x = 0.55$  tons,  $h_{ux} = 0.06$  tons

Maximum lateral force in the y direction on the pile,  $F_y = 0.55$  tons,  $h_{uy} = 0.06$  tons

Combined lateral force in two directions,

$$F_{\text{combination}} = h_{\text{umax}} = 0.09 \text{ tons}$$

$$\text{Condition: } h_{\text{umax}} \leq f \cdot H_n$$

$$0.09 \text{ ton} < 5.96 \text{ tons} \rightarrow \text{Fulfilling the AMAN requirement (OK)}$$

The Relationship between Allowable Lateral Capacity and Pile Length

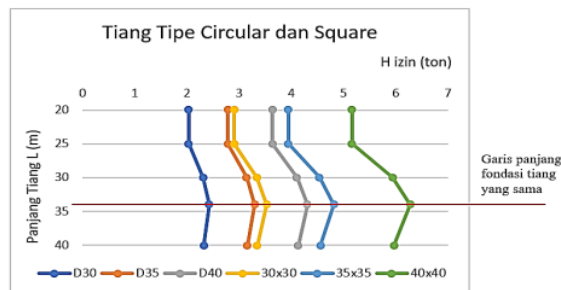

**Figure 7** The relationship between lateral bearing capacity and pile length, for circular and square pile types.



Figure 7 displays the outcomes of the graphical analysis depicting the relationship between the permitted lateral bearing capacity and the length of the pile for both circular and square cross-sections. Among the circular cross-sections, the D30 size yields the smallest permitted lateral bearing capacity, whereas the 40x40 square pile cross-section generates the largest permitted lateral bearing capacity. Notably, there are no significant differences observed in the lateral bearing capacity of the permit between the D35 circular cross-section and the 30x30 square cross-section. Furthermore, when considering piles with the same length, the 40x40 cross-section exhibits the highest permitted lateral bearing capacity, while the D30 pile section showcases the lowest permitted lateral bearing capacity.

#### The Outcomes of Lateral Pile Deflection

Table 4 presents the results of the lateral pile deflection calculation conducted using the P-Y method in the computer program application for various pile variations. The calculations include circular type piles with diameter variations of D30, D35, D40, and square type piles with cross-sectional size variations of 30x30, 35x35, 40x40. The pile lengths considered in the calculations are 20m, 25m, 30m, 34m, and 40m.

**Table 4** The results of lateral deflection calculation with variations in pile dimensions and pile length L

| L (m) | Deflection ( $10^{-3}$ mm) |      |      |        |       |       |
|-------|----------------------------|------|------|--------|-------|-------|
|       | Circular                   |      |      | Square |       |       |
|       | D30                        | D35  | D40  | 30x30  | 35x35 | 40x40 |
| 20    | 1.81                       | 0.49 | 0.42 | 1.04   | 0.48  | 0.22  |
| 25    | 1.91                       | 1.02 | 0.36 | 1.16   | 0.41  | 0.23  |
| 30    | 1.95                       | 1.10 | 0.34 | 1.15   | 0.40  | 0.24  |
| 34    | 1.85                       | 1.06 | 0.33 | 1.09   | 0.39  | 0.25  |
| 40    | 0.68                       | 0.68 | 0.36 | 0.73   | 0.40  | 0.27  |

According to the specifications outlined in SNI 8460 of 2017, the maximum lateral deflection should not exceed the permissible lateral deflection. As a general guideline, the permissible lateral deflection for pile foundations should not surpass 2.50 cm or 0.25 mm.

As per the provisions stated in SNI 8460 of 2017, the maximum lateral deflection in the

lateral direction must not exceed the permissible lateral deflection. In general, the allowable lateral deflection for pile foundations should not exceed 2.50 cm or 0.25 mm.

The calculation results for all variations in pile length and dimensions can be found in the appendix.

**The Relationship between Lateral Deflection and Pile Length**

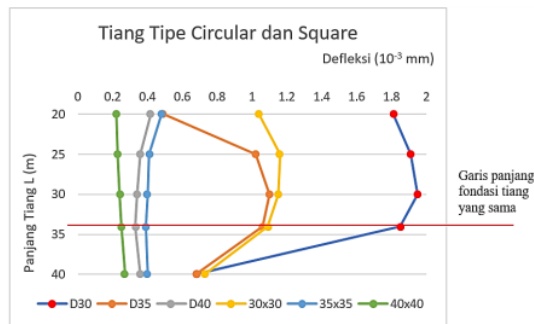

**Figure 8** The relationship between lateral deflection and pile length, for circular and square pile types

Figure 8 illustrates the relationship between the length of the foundation pile and the lateral deflection for square and circular cross-section types. The results of the graphical analysis indicate that the 40x40 square-section exhibits the smallest lateral deflection, while the D30 circular-section demonstrates the largest lateral deflection. Additionally, the 35x35 square cross-section exhibits slightly larger lateral deflections compared to the circular D40 cross-section. Furthermore, when comparing the 35x35 square cross-section, the D35 circular cross-section, and the 30x30 square cross-section, it is observed that the D30 circular cross-section has significantly larger lateral deflection values across variations in the length of the foundation piles (L=20m to L=35m). Conversely, for a pile length of 40m (same length), the graph reveals that pile foundations with circular sections D30, D35, and square sections 30x30 are closely grouped together, indicating relatively similar deflection values with minimal variation.

**5. CONCLUSIONS**

Based on the results of calculations and graphical analysis using the computer program method and the Brinch Hansen method for the case study of the Customs Building in Banjarmasin, South Kalimantan, the following conclusions can be drawn

regarding the effect of foundation depth and dimensions on the design of pile foundations to withstand lateral forces:

1. The comparison between circular and square cross-sections is that a square cross-section yields a larger permitted lateral bearing capacity compared to a circular cross-section. Meanwhile, the lateral deflection produced by the square section is smaller than the circular section.
2. The longer the pile, the greater the permitted lateral bearing capacity and the smaller the resulting lateral deflection.
3. In a square cross-section, the larger the cross-sectional size and the longer the pile, the greater the permitted lateral bearing capacity and the smaller the lateral deflection.
4. In a circular cross-section, the smaller the cross-sectional size and the longer the pile, the greater the lateral deflection and the smaller the permitted lateral bearing capacity produced by the pile.

## REFERENCES

- [1] Aulia, Rafini dan Hikmad Lukman, Titik Penta Artiningsih, 2019, Analisis Gaya Lateral Pada Pondasi Tiang Pancang Square, Bandung, PT. Ultra Jaya Milk Industri.
- [2] Badan Standarisasi Nasional Indonesia (SNI 8460:2017), 2017, Fondasi Tiang.
- [3] Badan Standarisasi Nasional Indonesia (SNI 8460:2017), 2017, Uji Fondasi Tiang.
- [4] Das, Braja M, 1995, Mekanika Tanah (Prinsip-Prinsip Rekayasa Geoteknik) Jilid II, Jakarta, Erlangga.
- [5] Dirgananta, Muhammad Fahri, 2018, Perencanaan Ulang Pondasi Tiang Pancang Dengan Variasi Diameter Menggunakan Metode Mayerhoff, Aoki & De Alencar dan Luciano Decourt, Yogyakarta, Tugas Akhir Universitas Islam Indonesia.
- [6] Huda, Cahiril, Eka Priadi dan Ahmad Faisal, 2020, Kajian Daya Dukung Lateral Tiang Pancang Menggunakan Analisa Numerik, Pontianak, Jurnal Teknik Sipil, Fakultas Teknik Universitas Tanjungpura Pontianak.
- [7] Jaya, Darwin Dirta, Sjachrul Balamba dan Alva N. Sarajar, 2016, Analisis Daya Dukung Tiang Pancang Pada Pembangunan Manado Town Square III Dengan

- Metode Wave Equation, Manado, *Jurnal Teknik Sipil*, Fakultas Teknik Universitas Sam Ratulangi.
- [8] PT. Somif Borneo Perkasa, 2020, Laporan Hasil Penyelidikan Tanah untuk Proyek Pembangunan Gedung Bea Cukai Banjarmasin Kota Banjarmasin, Kalimantan Selatan.
- [9] PT. Yodya Karya (Persero) Wilayah III, 2020, Laporan Perhitungan Struktur Atas dan Struktur Bawah Jasa Konsultasi Perencanaan Pembangunan Gedung dan Sarpras Kantor Wilayah DJBC Kalimantan Bagian Selatan, Kalimantan Selatan.
- [10] Laurent, Dave dan Alfred Jonathan Susilo, 2018, Pengaruh Void Pada Penampang Tiang Pondasi Terhadap P-Y Curve. Jakarta. *Jurnal Teknik Sipil Fakultas Teknik Universitas Tarumanegara*.
- [11] Nasrullah, Yusep Muslih P dan Niken Silmi Surjandari, 2017, Analisis Defleksi *Lateral* Tiang Tunggal Pada Tanah Kohesif, Surakarta, *Jurnal Teknik Sipil Fakultas Teknik Universitas Sebelas Maret*.

# Behavior of foundation piles resisting lateral forces in soft soil

## ORIGINALITY REPORT

15%

SIMILARITY INDEX

10%

INTERNET SOURCES

6%

PUBLICATIONS

6%

STUDENT PAPERS

## PRIMARY SOURCES

|   |   |    |
|---|---|----|
| 1 | Submitted to Defense University<br>Student Paper  | 3% |
| 2 | Haojun Yu, Sheqin Peng, Qihua Zhao. "Field Tests of the Response of Single Pile Subjected to Lateral Load in Gravel Soil Sloping Ground", Geotechnical and Geological Engineering, 2018<br>Publication  | 2% |
| 3 | <a href="https://scholarsarchive.byu.edu">scholarsarchive.byu.edu</a><br>Internet Source  | 1% |
| 4 | <a href="https://dspace.uui.ac.id">dspace.uui.ac.id</a><br>Internet Source  | 1% |
| 5 | Junpeng Zhou, Xuefeng Huang, Jun Yuan, Jilu Zhang, Xueming Wang. "Comparative Study on the Influence of Pile Length and Diameter on Bearing Capacity and Efficiency of Root Piles, Straight-Shaft Piles and Pedestal Piles", Arabian Journal for Science and Engineering, 2021<br>Publication | 1% |

|    |  |      |
|----|--|------|
| 6  | <a href="http://repository.narotama.ac.id">repository.narotama.ac.id</a><br>Internet Source  | 1 %  |
| 7  | <a href="http://jtiulm.ti.ft.ulm.ac.id">jtiulm.ti.ft.ulm.ac.id</a><br>Internet Source  | 1 %  |
| 8  | <a href="http://etd.repository.ugm.ac.id">etd.repository.ugm.ac.id</a><br>Internet Source  | 1 %  |
| 9  | <a href="http://ejournal.unsrat.ac.id">ejournal.unsrat.ac.id</a><br>Internet Source  | 1 %  |
| 10 | <a href="http://fdocuments.in">fdocuments.in</a><br>Internet Source  | 1 %  |
| 11 | <a href="http://ojs2.pnb.ac.id">ojs2.pnb.ac.id</a><br>Internet Source  | 1 %  |
| 12 | Ahmed Al-Gharbawi. "Decrease in failure load of inclined driven piles by using Allpile program", MATEC Web of Conferences, 2018<br>Publication | <1 % |
| 13 | <a href="http://repository.unhas.ac.id">repository.unhas.ac.id</a><br>Internet Source  | <1 % |
| 14 | Submitted to Middle East Technical University<br>Student Paper   | <1 % |
| 15 | <a href="http://123dok.com">123dok.com</a><br>Internet Source  | <1 % |
| 16 | L. T. W. N. Kusuma, A. A. Ramadhan, H. D. P. Anggriyanti. "The Quality Function  | <1 % |

Deployment (QFD) - based evaluation of Malang Waste Bank management", 2015 IEEE International Conference on Industrial Engineering and Engineering Management (IEEM), 2015

Publication

---

17

Ahmed M.A. Nasr. "Experimental and theoretical studies of laterally loaded finned piles in sand", Canadian Geotechnical Journal, 2014

Publication

---

18

[iopscience.iop.org](http://iopscience.iop.org)

Internet Source

---

19

A. M. A. Nasr, S. V. Krishna Rao. "Behaviour of laterally loaded pile groups embedded in oil-contaminated sand", Géotechnique, 2016

Publication

---

20

Sanjeev Kumar, Latika Lalvani, Maher Omar. "Nonlinear Response of Single Piles in Sand Subjected to Lateral Loads using khmax Approach", Geotechnical and Geological Engineering, 2006

Publication

---

21

Tasya Wijaya, Oki Setyandito, Novandy. "STABILITY ANALYSIS OF JETTY PILES DUE TO LATERAL FORCE (CASE STUDY: TOURISM HARBOR)", IOP Conference Series: Earth and Environmental Science, 2022

<1 %

<1 %

<1 %

<1 %

<1 %

22

[www.simpel.lpse.kemenkeu.go.id](http://www.simpel.lpse.kemenkeu.go.id)  
Internet Source

<1 %

---

23

[dissertations.umi.com](http://dissertations.umi.com)  
Internet Source

<1 %

---

---

Exclude quotes Off

Exclude matches Off

Exclude bibliography Off