

Nutrient Concentration Control System in Hydroponic Plants Based on Fuzzy Logic

Nurmahaludin

Dept. of Electronics Engineering
Politeknik Negeri Banjarmasin
Banjarmasin, Indonesia
mahaludin@poliban.ac.id

Gunawan R. Cahyono

Dept. of Mechanical Engineering
Lambung Mangkurat University
Banjarmasin, Indonesia
gunawan.cahyono@ulm.ac.id

Joni Riadi

Dept. of Electrical Engineering
Politeknik Negeri Banjarmasin
Banjarmasin, Indonesia
joni_riadi@poliban.ac.id

Abstract— The purpose of this study was to control nutrient concentrations in hydroponic plants according to predetermined values. If the density is high, dilution is needed, whereas if the density is low, additional nutrients are needed. So far, nutrient concentration monitoring has been carried out using a Total Dissolve Solid (TDS) measuring instrument and done manually. So that if there is a delay, lack or excess of nutrition and water, it will result in not optimal plant growth. The control system uses a controller based on fuzzy logic with the Sugeno method. The input of the controller is error and delta error, while the output of the controller will adjust the angle of the servo motor that drives the nutrient and water valve openings. The test results with an initial concentration value of 400 ppm (below the set point) obtained a settling time at 138 seconds, while the set point was reached at 157 seconds where the output value was 601.26 ppm. For testing with an initial concentration value of 700 ppm (above the set point), the settling time was obtained at 76 seconds and the set point was reached at 143 seconds, namely 601.45 ppm. The system achieves control objectives using a designed fuzzy logic controller

Keywords—control system, fuzzy logic, hydroponic

INTRODUCTION

Hydroponic technology can be interpreted as an effort to cultivate plants without soil media by utilizing nutrient solutions in water. This is a solution to limited land for farmers or residents who want to cultivate vegetables in urban areas. In hydroponic cultivation, the thing that must be considered is that each type of plant requires nutrients with different concentrations [1]. Controlling nutrient concentration is important because it is to keep the concentration level of the nutrient solution at the desired value according to the reference value. If the density is high, dilution is needed, whereas if the density is low, additional nutrients are needed.

Research on control systems and nutrition in hydroponic plants, among others, controlling pH and conductivity of water using sensors and microcontrollers [2][3]. In this study, the control process was carried out through a programmed microcontroller. The next research development is the provision of nutrition to hydroponic plants through remote control using an Arduino microcontroller which is connected to a Wi-Fi module [4].

Internet of things-based control technology is currently also penetrating hydroponic plants such as in [5] and [6] where sensors and microcontrollers can be monitored and controlled via smartphones. Meanwhile, [7] utilized IoT to regulate pH, TDS sensor, and temperature using K-Nearest Neighbors (KNN) for classification of nutritional conditions.

In connection with the control method based on fuzzy logic, research has been carried out to control the electrical conductivity (EC) and pH in hydroponic plants of the NFT type [8] and the regulation of electrical conductivity (EC) using two pumps, namely pump A which contains nutrients and pump B which contains water [9]. Meanwhile, [10] used fuzzy mamdani to determine the parts per million (PPM) value prediction.

Although the control system as mentioned above can be done, in the process of regulating nutrient concentration, two tanks containing water and nutrient solution are controlled on-off. Arduino will activate or deactivate the tank valve containing water or nutrients and then flow it to hydroponic plants. The on-off control method can be interpreted as a valve that opens completely (totally on) or completely closes (totally off) if the output value is not the same as the set point value.

In this research, a fuzzy control algorithm is used where the valve opening process depends on the angular motion of the servo motor based on the output value of the controller.

A. Fuzzy Logic

Basically, humans recognize objects by providing qualitative classifications, such as long, short, fast, slow, large, small, and so on. The boundary between one set and another set is unclear or fuzzy. For example, the speed of 50 km / hour is fast, rather fast or a little slow. The concept of fuzzy logic then appears to solve this problem.

Membership of an element in a fuzzy set is expressed in the degree of membership. So that the speed of 50 km/hour can be a member of the “rather fast” association with a membership degree of 0.8 and can also be a member of the “fast” set with a membership degree of 0.2. To express the degree of membership in a fuzzy set, a membership function is used. The membership function is expressed as a curve that maps the input into the degrees of membership. Each member in a fuzzy set has a degree of membership, which is expressed as a number between 0 and 1.

A fuzzy system has three important processes in it, namely:

1. Fuzzification
Fuzzification will change the input value from crisp value to fuzzy value based on its membership function.
2. Inference
Inference is a process of mapping fuzzy input using rules to produce fuzzy output.
3. Defuzzification

This process will change the fuzzy output value to a crisp value again

Each member in a fuzzy set has a degree of membership, which is expressed in a number between 0 and 1. To express the degree of membership of each member in a fuzzy set, a membership function is used. The membership function is expressed as a curve that maps the input into the degrees of membership.

B. Fuzzy Logic Based Control System

The control system is the process of setting one or more variables so that they are at a certain value or value range. Besides keeping the system output at the desired value, the control system also aims to obtain optimal performance. The control system diagram based on fuzzy logic controller is shown in Fig. 1.

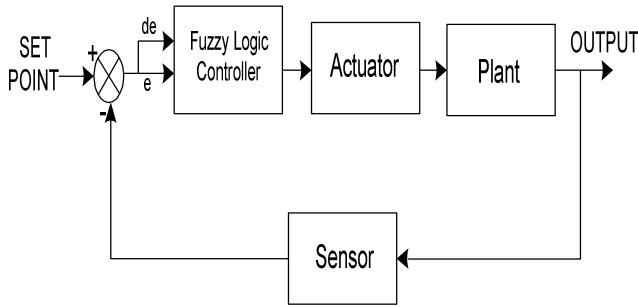

Fig. 1. Block diagram of fuzzy logic control system

Plant is a process to be controlled, in this case the concentration of nutrient solution. The control system begins by providing a set point value. The system output is measured using a sensor and then compared with the set point to determine the resulting error.

$$e(t) = SP - PV \quad (1)$$

where $e(t)$ is the error value at time t , SP is the set point value, and PV (present value) is the measured output value of the sensor. If there is an error, the controller will process it using a control algorithm that has been programmed. There are two inputs to the fuzzy logic controller (FLC), namely error (e) and delta error (de), where the delta error is the change of error $e(t)$ and previous error $e(t-1)$, formulated by (2).

$$\delta e(t) = e(t) - e(t - 1) \quad (2)$$

Output of the controller will adjust the angle of the servo motor to open the nutrient solution or water valve. Conversely, if the error value is positive, it indicates that the plant is approaching the threshold of nutrient deficiency so that the nutrient solution valve needs to be opened by means of a servo motor movement. If the error value is negative, it indicates that the plant is approaching the threshold of nutrient excess. So that the controller will drive the servo motor to open the water valve.

II. METHODS

The design of the hydroponic plant nutrient concentration control system is shown in Fig. 2. The nutrient solution tank contains a mixture of nutrient A (5ml) and nutrient B (5ml), while the water tank is used as a solution diluent.

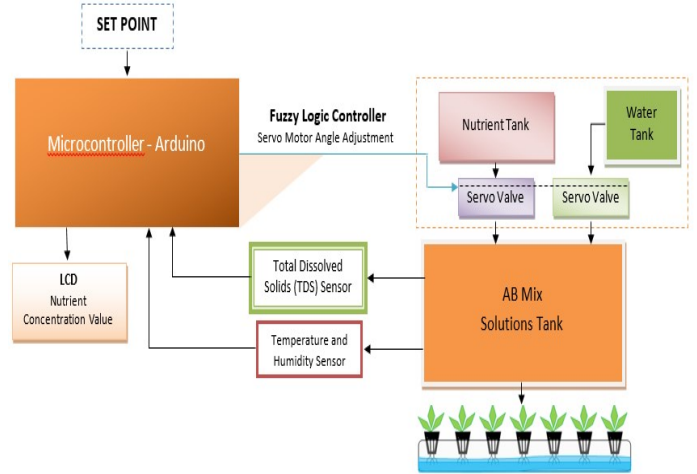

Fig. 2. Control system design for hydroponic concentration

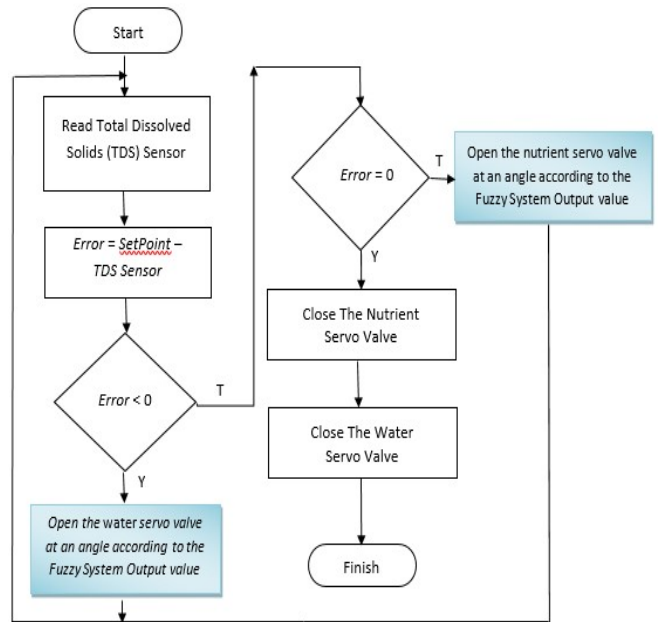

Fig. 3. Flowchart control process

The control process for adjusting the servo motor at the nutrient and water valve openings is shown in Fig. 3. In this study the Sugeno method was used, because it is simpler in the defuzzification process compared to Mamdani as in [11].

The fuzzy inference system flow diagram is shown in Fig. 4 where fuzzy control uses the "if-then" rule with the output being the angle value of the servo motor.

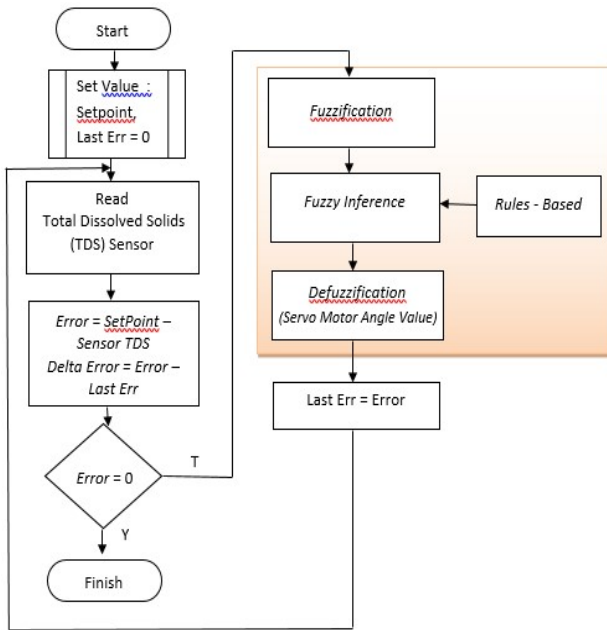

Fig. 4. Fuzzy inference system

A. Controller Design

The controller input is the error at the time of observation $e(t)$ and the delta error ($\delta e(t)$) which is the difference between the error at the time t minus the error at the time before ($t-1$). The output of the controller is a servo motor that moves from an angle of 0° to 70° as shown in Fig. 5.

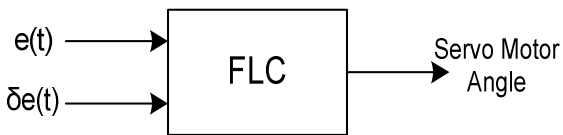

Fig. 5. Input-Output system

Input $e(t)$ is divided into 3 sets, namely small (S), medium (M), and big (B) as shown in Fig. 6.

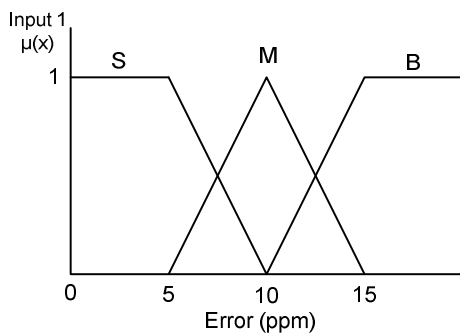

Fig. 6. Membership function of error

The membership function $e(t)$ in Fig. 6 is given :

$$\mu_{Small}[x] = \begin{cases} 1 & , x \leq 5 \\ \frac{10-x}{5} & , 5 \leq x \leq 10 \\ 0 & , x \geq 10 \end{cases} \quad (3)$$

$$\mu_{Medium}[x] = \begin{cases} 0 & ; x \leq 5 \text{ or } x \geq 15 \\ \frac{x-5}{5} & ; 5 \leq x \leq 10 \\ \frac{15-x}{5} & ; 10 \leq x \leq 15 \end{cases} \quad (4)$$

$$\mu_{Big}[x] = \begin{cases} 0 & , x \leq 10 \\ \frac{x-10}{5} & , 10 \leq x \leq 15 \\ 1 & , x \geq 15 \end{cases} \quad (5)$$

The input $\delta e(t)$ is divided into 3 sets, namely small (S), medium (M), and big (B) as shown in Fig. 7.

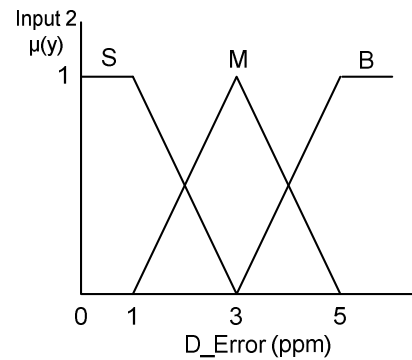

Fig. 7. Membership function of delta error

The membership function $\delta e(t)$ in Fig. 7 is given :

$$\mu_{Small}[y] = \begin{cases} 1 & , x \leq 1 \\ \frac{3-x}{2} & , 1 \leq x \leq 3 \\ 0 & , x \geq 3 \end{cases} \quad (6)$$

$$\mu_{Medium}[y] = \begin{cases} 0 & ; x \leq 1 \text{ or } x \geq 5 \\ \frac{x-1}{2} & ; 1 \leq x \leq 3 \\ \frac{5-x}{2} & ; 3 \leq x \leq 5 \end{cases} \quad (7)$$

$$\mu_{Big}[y]=\begin{cases} 0 & , x \leq 3 \\ \frac{x-3}{2} & , 3 \leq x \leq 5 \\ 1 & , x \geq 5 \end{cases} \quad (8)$$

Meanwhile, the output angle of the servo motor is divided into 5 singleton, which is the Sugeno method, namely very small (VS), small (S), medium (M), big (B), and very big (VB) as shown in Fig. 8.

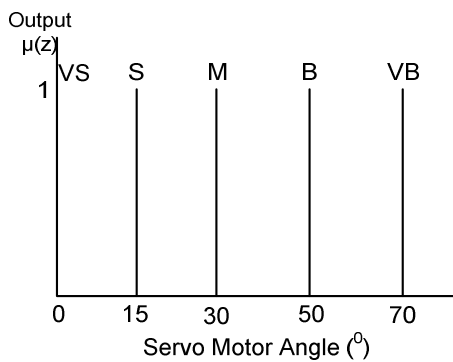

Fig. 8. Membership function of servo angle

B. Electronic Circuit Design

The electronic circuit design is shown in Fig. 9. The schematic above has the following pin out configuration:

1. The TDS sensor will be connected to pin A0 of the Arduino microcontroller. The sensor probe is placed in a nutrient solution tank where its concentration will be measured.
2. RTC and LCD use serial I2C respectively for data connected to an Arduino microcontroller.
3. Temperature and humidity sensors are connected to the D10 pin microcontroller
4. The servo motor is used to rotate the water valve and the nutrient valve connected to the D4 and D5 pins of the Arduino microcontroller.

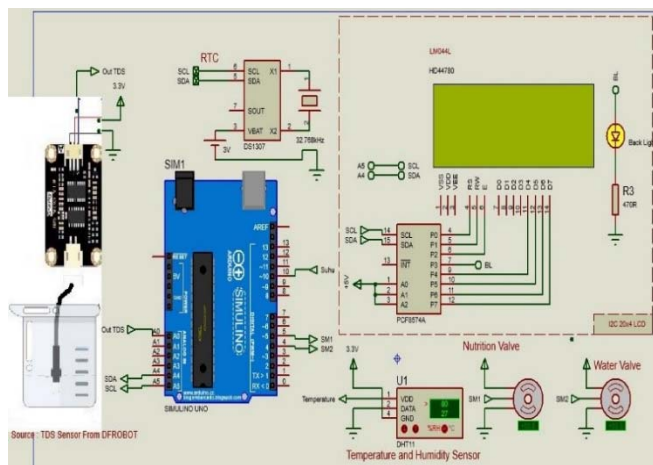

Fig. 9. Electronic Circuit

III. RESULT AND DISCUSSION

The process of regulating nutrient concentration through open water and nutrient valve in hydroponic planting tanks is as shown in Fig. 10.

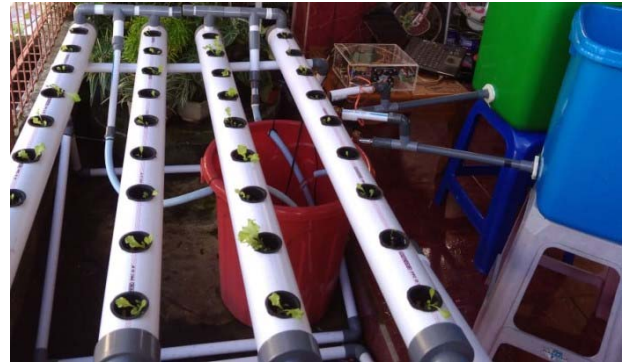

Fig. 10. Nutrient Concentration Regulation

The fuzzy rules has an if-then shape, with the operator connecting AND between the first input and the second input. Table 1 shows a table of fuzzy rules from a pre-compiled set.

TABLE I. RULES OF FUZZY CONTROLLER

$\delta e(t)$ $e(t)$	Small	Medium	Big
Small	VS	S	M
Medium	M	B	VB
Big	B	VB	VB

- Rule 1 : If error is small and delta error is small, then servo motor angle is very small
- Rule 2 : If error is small and delta error is medium, then servo motor angle is small
- Rule 3 : If error is small and delta error is big, then servo motor angle is medium
- Rule 4 : If error is medium and delta error is small, then servo motor angle is medium
- Rule 5 : If error is medium and delta error is medium, then servo motor angle is big
- Rule 6 : If error is medium and delta error is big, then servo motor angle is very big
- Rule 7 : If error is big and delta error is small, then servo motor angle is big
- Rule 8 : If error is big and delta error is medium, then servo motor angle is very big
- Rule 9 : If error is big and delta error is big, then servo motor angle is very big

The test is carried out on two different conditions, the first is below the set point (dilute solution) and the second is above the set point (concentrated solution). The set point is set at 600 ppm. In testing with an initial value of 400 ppm solution (below the set point), a response graph was obtained as shown in Fig. 11. Data is retrieved in realtime every second. From the graph, it can be seen that the system reached settling time at 138 seconds with an output value of 571.78. While the set point is reached at 157 seconds where the output value is 601.26.

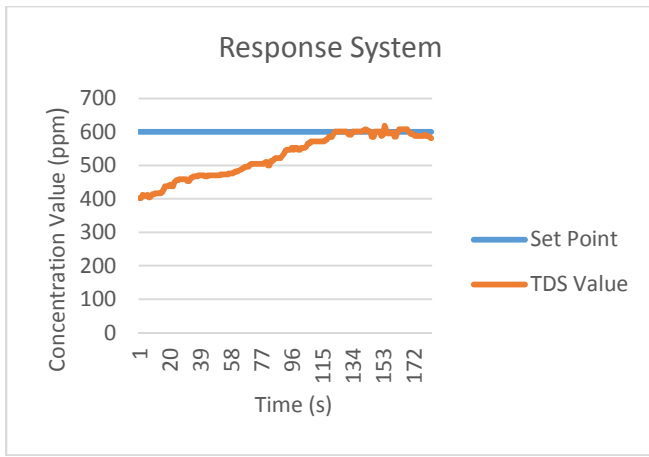

Fig. 11. Response system with initial value 400 ppm

Table 2 shows the response data with a sampling period every 10 seconds. In the initial conditions, the Arduino microcontroller ordered the nutrient valve to fully open through the servo motor angle of 70 degrees. This nutrient valve continues to open to increase the concentration of the solution up to 600 ppm. When the concentration reaches 600 ppm, the nutrient valve closes. If then the concentration value exceeds the set point, this means that the solution needs to be diluted so that the water tap then opens. Opening the lid between the nutrient valve and the water valve means that the system tries to balance so that the set point is maintained.

The test with the initial conditions of 700 ppm (above the set point) is shown in Fig. 12. The system achieved a settling time at 76 second with an output of 630.47. Then when at 143 second reaches the best value, which is 601.45 ppm.

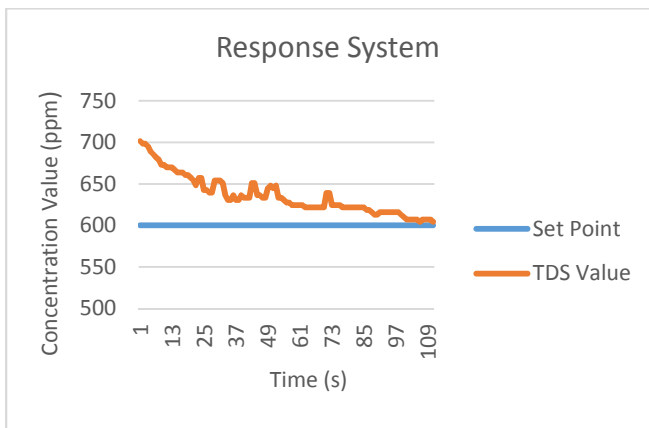

Fig. 12. Response system with initial value 700 ppm

IV. CONCLUSION

Controlling the concentration of the solution is done by adjusting the valve opening of the water and nutrient tank using a fuzzy logic controller. The input fuzzy logic controller is the amount of error and delta error generated, while the output is the angle of the servo motor on the water and nutrient valve.

In testing with the initial conditions of the 400 ppm solution, the system achieved a settling time of 5% at 138 seconds with an output value of 571.78. While the set point is reached at 157 seconds where the output value is 601.26. In this condition the nutrient valve opens to increase the concentration of the solution.

In testing with an initial condition of 700 ppm, the system reaches a settling time of 5% at 76 seconds with an output of 630.47. Then when at 143 second reaches the best value, which is 601.45 ppm. This process is a dilution by adding water to the solution.

When the system has reached the 600 ppm set point, the system will try to maintain this value by balancing nutrients and water valve.

TABLE II. RESPONSE EVERY 10 SECONDS

Time	Set Point	TDS Value
6:19:10 PM	600	401.82
6:19:20 PM	600	414.16
6:19:30 PM	600	437.5
6:19:40 PM	600	456.28
6:19:50 PM	600	461.75
6:20:00 PM	600	470.04
6:20:10 PM	600	470.04
6:20:20 PM	600	472.83
6:20:30 PM	600	486.94
6:20:40 PM	600	504.28
6:20:50 PM	600	507.22
6:21:00 PM	600	522.07
6:21:10 PM	600	546.51
6:21:20 PM	600	552.75
6:21:28 PM	600	571.78
6:21:30 PM	600	571.78
6:21:40 PM	600	578.24
6:21:47 PM	600	601.26
6:22:00 PM	600	591.31
6:22:10 PM	600	604.61
6:22:20 PM	600	584.75
6:22:30 PM	600	601.26
6:22:40 PM	600	588.02
6:22:50 PM	600	591.31
6:23:00 PM	600	618.72
6:23:10 PM	600	595.47
6:23:20 PM	600	607.97
6:23:30 PM	600	594.62
6:23:40 PM	600	588.02

REFERENCES

- [1] T. E. Tallei, I. F. M. Rumengan, and A. A. Adam, *Hidroponik untuk Pemula*, vol. 1, no. 1, 2017.
- [2] H. Helmy, A. Rahmawati, S. Ramadhan, T. A. Setyawan, and A. Nursyahid, "Pemantauan dan Pengendalian Kepekatan Larutan Nutrisi Hidroponik Berbasis Jaringan Sensor Nirkabel," *J. Nas. Tek. Elektro dan Teknol. Inf.*, vol. 7, no. 4, 2018.
- [3] S. Umamaheswari, A. Preethi, E. Pravin, and R. Dhanusha, "Integrating scheduled hydroponic system," *2016 IEEE Int. Conf. Adv. Comput. Appl. ICACA 2016*, pp. 333–337, 2017.
- [4] P. Sihombing, N. A. Karina, J. T. Tarigan, and M. I. Syarif, "Automated hydroponics nutrition plants systems using arduino uno microcontroller based on android," *J. Phys. Conf. Ser.*, vol. 978, no. 1, 2018.
- [5] S. Tembe, S. Khan, and R. Acharekar, "IoT based Automated Hydroponics System," pp. 67–71, 2018.
- [6] P. Sihombing, M. Zarlis, and Herryance, "Automatic Nutrition Detection System (ANDES) for Hydroponic Monitoring by using Micro controller and Smartphone Android," *Proc. 2019 4th Int. Conf. Informatics Comput. ICIC 2019*, 2019.
- [7] D. Adidrana and N. Surantha, "Hydroponic Nutrient Control System based on Internet of Things and K-Nearest Neighbors," *2019 Int. Conf. Comput. Control. Informatics its Appl. Emerg. Trends Big Data Artif. Intell. IC3INA 2019*, pp. 166–171, 2019.
- [8] D. Yolanda, H. Hindersah, F. Hadiatna, and M. A. Triawan, "Implementation of real-time fuzzy logic control for NFT-based hydroponic system on Internet of Things environment," *Proc. 2016 6th Int. Conf. Syst. Eng. Technol. ICSET 2016*, pp. 153–159, 2017.
- [9] D. Yolanda, L. Arief, T. A. Sundara, M. Deza, and D. Oktavia, "Control of Electrical Conductivity for NFT Hydroponic Systems using Fuzzy Logic and Android Environment," *2018 Int. Conf. Inf. Technol. Syst. Innov. ICITSI 2018 - Proc.*, pp. 508–514, 2018.
- [10] P. Musa, H. Sugeru, and H. F. Mufza, "An intelligent applied Fuzzy Logic to prediction the Parts per Million (PPM) as hydroponic nutrition on the based Internet of Things (IoT)," *Proc. 2019 4th Int. Conf. Informatics Comput. ICIC 2019*, no. 1, 2019.
- [11] J. S. M. Lenord Melvix and C. Sridevi, "Design of efficient hydroponic nutrient solution control system using soft computing based solution grading," *2014 Int. Conf. Comput. Power, Energy, Inf. Commun. ICCPEIC 2014*, pp. 148–154, 2014.